

# PROLAC HCPN SP

## Centrifugal pump



### APPLICATION

Due to the choice of materials and its design, PROLAC HCPN SP (Self-Priming) is suitable for applications requiring a high level of hygiene, gentle handling of the product and resistance to chemical attack. The HCP SP pump is particularly suitable for pumping liquids containing air or gas without losing its pumping capacity. It can be used in the food-processing, pharmaceutical and chemical industries. Its main application is the return of the CIP cleaning system.

### OPERATING PRINCIPLE

The PROLAC HCPN SP is a self-priming pump that eliminates the need for a vacuum pump or other devices such as foot valves or additional pipes.

The pump needs to be primed with liquid only once before start up. When the pump is turned on, it sucks the air or gas present in the suction pipe, mixing it with the liquid in the pump body. The centrifugal forces push the mixture of liquid and gas towards the separator tank where it loses speed. Because of gravity, the liquid remains at the bottom of the separator tank and is driven back to the pump body through the return pipe, while the air or gas is released through the discharge pipe. In this way, the air or gas is continuously being removed from the suction pipe until the liquid reaches the pump body and the pump begins to operate like a normal centrifugal pump.

It is very important the sucked air is released through the discharge pipe without any back pressure.

It is not advisable to reduce the hydraulic performance of the pump by resizing the impeller or lowering the speed by means of a frequency converter, since it will have negative repercussions on the pump's suction capacity.

### DESIGN AND FEATURES

The PROLAC HCPN SP has the same components as the PROLAC HCPN. The key difference between the two pumps is the body. The impeller, seal and all the other parts are the same in both pumps. The body of the PROLAC HCPN SP includes a separator tank and a non-return valve, ensuring high levels of efficiency.

### TECHNICAL SPECIFICATIONS

#### Materials

Parts in contact with the product	1.4404 (AISI 316L)
Other steel parts	1.4301 (AISI 304)
Gaskets in contact with the product	EPDM

**Mechanical seal**

Rotary part	silicon carbide (SiC)
Stationary part	carbon (C)
Gaskets	EPDM

**Surface finish**

Internal	bright polish Ra ≤ 0,8 µm
External	matt

**Connections**

DIN 11851 (Estándar)  
 CLAMP-OD (ASME BPE / DIN 32676 serie C)  
 SMS 1145

**Operating limits**

Nominal pressure	1600 kPa (16 bar)	232 PSI
Temperature range	-10°C to 120°C	14° to 248°F
Temperature, maximum SIP cleaning time	140°C for 30 min	284°F
Maximum flow	110 m³/h	484 US GPM
Maximum differential head	60 m	484 ft
Maximum speedx	3600 rpm	

**MOTOR**

NEMA Premium Efficiency three-phase induction motor, C-face and foot mounted.

**OPTIONS**

Different types of connections.

Mechanical seal: SiC/SiC.

Double mechanical seal.

Gaskets: FPM.

Motor with other voltages, frequencies, mechanical protections.

Motor for explosive atmospheres or with enhanced safety level.

**DIMENSIONS**

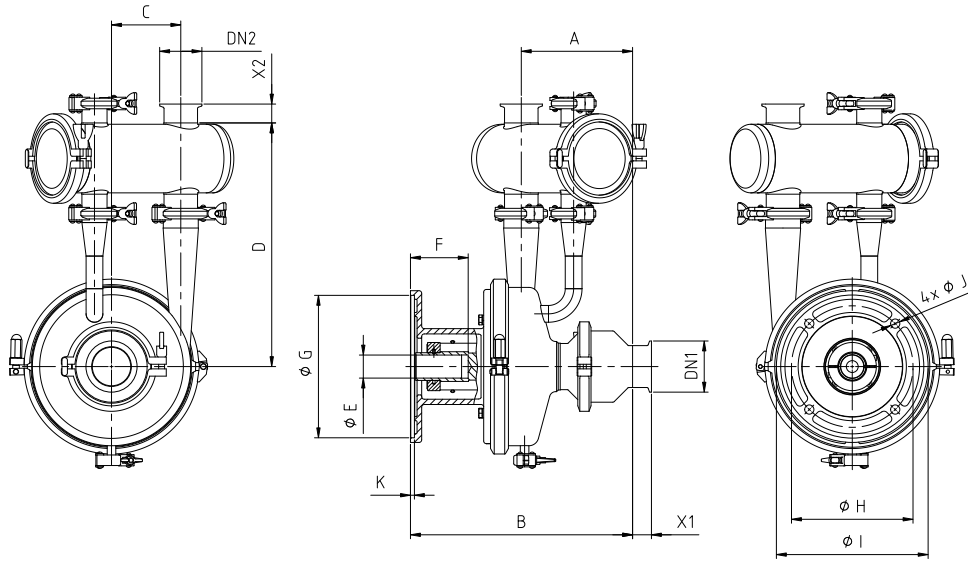

01.033.32.0021

Pump	Motor	DN1	DN2	A	B	C	D	E	F	G	H	I	ØJ	K	X1	X2	kg
HCPN 50-150	182/184TC	2½"	2"	6,85	13,50	2,83	12,95	1,13	2,95	8,50	7,25	9,06	0,55	0,24	1,13	1,13	20
	213/215TC							1,38	3,44								20
HCPN 50-190	213/215TC	2½"	2"	6,65	13,27	4,13	14,57	1,38	3,44	8,50	7,25	9,06	0,55	0,24	1,13	1,13	26
	254/256TC							1,63	4,07			9,84					26
HCPN 65-215	254/256TC	3"	2½"	7,60	15,71	4,72	17,01	1,63	4,07	8,50	7,25	9,84	0,55	0,24	1,13	1,13	38

Dimensions in inches

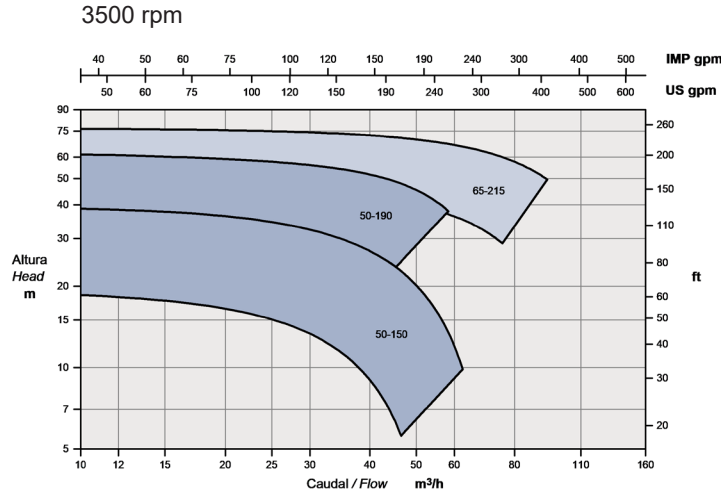

01.033.32.0020